



COMPONENTES:

- 1 Cara de roce rotante
- 2 Cara de roce fija
- 3 Fuelle
- 3a Junta elastómerica
- 4 Muelle
- 5 Anillo
- 5a Anillo de retención
- 5b Armadura metálica

SECTORES:



CARACTERÍSTICAS:

- No equilibrado.
- Sentido rotación independiente.
- Muelle simple cilíndrico.

LÍMITES OPERATIVOS:

$d_1 = 8 \div 40 \text{ mm}$ $p = 12 \text{ kg/cm}^2$

$v = 10 \text{ m/s}$ $t = -20 \div +120^\circ\text{C} (*)$

(*) La resistencia a la temperatura está condicionada por el material de las juntas secundarias utilizadas.

Los límites operativos vienen condicionados por el factor PV, que está determinado tanto por las características del sistema de sellado como por las de la aplicación.

DESCRIPCIÓN:

Sello mecánico de construcción simple para uso general.



TABLA DIMENSIONAL

Medidas en mm

Eje	Parte rotante			Parte fija					Longitud total
	d ₃	d ₄	l ₃	d ₆	d ₇	l ₄	l ₅	l ₆	
8	22	27	15.5	14	26.00	5.5	0.5	4.5	21.0
10	22	27	15.5	14	26.00	5.5	0.5	4.5	21.0
11	22	27	15.5	14	26.00	5.5	0.5	4.5	21.0
12	22	27	15.5	14	26.00	5.5	0.5	4.5	21.0
13 A	28	33	18.0	17	29.50	8.0	1.0	6.0	26.0
13 B	32	37	13.0	17	29.50	8.0	1.0	6.0	21.0
14 B	28	33	18.0	17	29.50	8.0	1.0	6.0	26.0
14 C	28	33	22.0	19	23.10	6.0	1.2	3.0	28.0
14 A	32	37	13.0	17	29.50	8.0	1.0	6.0	21.0
15 A	28	33	18.0	17	29.50	8.0	1.0	6.0	26.0
15 B	32	37	13.0	17	29.50	8.0	1.0	6.0	21.0
16 C	28	33	18.0	17	29.50	8.0	1.0	6.0	26.0
16 F	28	33	23.0	21	26.90	7.0	1.5	4.0	30.0
16 E	31	36	29.0	17	29.50	8.0	1.0	6.0	37.0
16 A	32	37	13.0	17	29.50	8.0	1.0	6.0	21.0
16 D	32	37	13.0	17	42.00	8.0	1.0	6.0	21.0
16 B	33	38	16.3	17	29.50	8.0	1.0	6.0	24.0
18 A	32	37	24.0	20	42.00	8.0	1.0	6.0	32.0
18 B	32	37	24.0	25	30.90	8.0	1.5	4.0	32.0
19.05	32	37	19.0	22	35.00	10.2	1.2	7.8	24.0
19.05	32	37	22.0	22	35.00	10.2	1.2	7.8	32.2
20 A	32	37	22.0	22	42.00	8.0	1.0	6.0	30.0
20 B	44	49	14.0	22	42.00	8.0	1.0	6.0	22.0
22 A	39	44	25.0	30	35.40	8.0	2.0	4.0	33.0
22	44	49	14.0	23	42.00	8.0	1.0	6.0	22.0
25.4	42	47	27.2	29	41.25	11.0	1.5	8.5	38.2
30 B	52	57	28.0	33	52.00	12.0	1.5	8.5	40.0
30A	60	65	22.0	33	52.00	12.0	1.5	8.5	34.0
31.75	52	57	49.2	34	47.62	11.0	1.5	8.5	60.2
40	63	68	35.0	45	68.00	12.0	1.5	8.5	47.0

Medidas sujetas a variaciones o modificaciones.

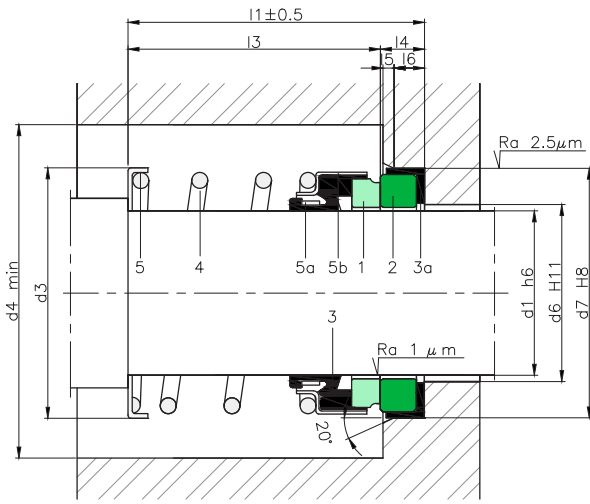